

CLARKE®



9" BANDSAW MODEL NO: CBS225

PART NO: 6460133

OPERATION & MAINTENANCE INSTRUCTIONS



ORIGINAL INSTRUCTIONS

GC0720 ISS 3

INTRODUCTION

Thank you for purchasing this CLARKE Bandsaw.

Before attempting to operate the machine, it is essential that you read this manual thoroughly and carefully follow all instructions given. In doing so you will ensure the safety of yourself and that of others around you, and you can also look forward to the product giving you long and satisfactory service.

GUARANTEE

This CLARKE product is guaranteed against faulty manufacture for a period of 12 months from the date of purchase. Please keep your receipt as proof of purchase.

This guarantee is invalid if the product is found to have been abused or tampered with in any way, or not used for the purpose for which it was intended.

Faulty goods should be returned to their place of purchase, no product can be returned to us without prior permission.

This guarantee does not effect your statutory rights.

ENVIRONMENTAL PROTECTION

Recycle unwanted materials instead of disposing of them as waste. All unwanted accessories and packaging should be sorted and taken to a recycling centre for disposal in a manner which is compatible with the environment.

ENVIRONMENTAL RECYCLING POLICY



Through purchase of this product, the customer is taking on the obligation to deal with the WEEE in accordance with the WEEE regulations in relation to the treatment, recycling & recovery and environmentally sound disposal of the WEEE.

In effect, this means that this product must not be disposed of with general household waste but according to the laws governing Waste Electrical and Electronic Equipment (WEEE) at a recognised disposal facility.

SAFETY WARNINGS



CAUTION: FAILURE TO FOLLOW THESE PRECAUTIONS COULD RESULT IN PERSONAL INJURY, AND/OR DAMAGE TO PROPERTY.

WORK ENVIRONMENT

1. **Keep the work area clean and well lit.** Cluttered and dark areas invite accidents.
2. **Do not operate power tools in explosive atmospheres, such as in the presence of flammable liquids, gases or dust.** Power tools create sparks which may ignite the dust or fumes.
3. **Keep children and bystanders away while operating a power tool. Anyone entering the work area must wear personal protective equipment.** Distractions can cause you to lose control and fragments of work or a broken disc may fly away and cause injury.
4. **Store power tools properly when not in use.** Abrasive products should be stored in a dry, secure place out of the reach of children.
5. Please read these instructions carefully and retain for future reference.

ELECTRICAL SAFETY

1. **Power tool plugs must match the outlet. Never modify the plug in any way. Do not use adapter plugs with earthed (grounded) power tools.** Unmodified plugs and matching outlets will reduce the risk of electric shock.
2. **Do not expose power tools to rain or wet conditions.** Water entering a power tool will increase the risk of electric shock.
3. **Do not abuse the cord. Never use the cable for carrying, pulling or unplugging the power tool. Keep the cable away from heat, oil, sharp edges or moving parts.** Damaged or entangled cables increase the risk of electric shock.
4. **When operating a power tool outdoors, use an extension cable suitable for outdoor use.** Use of a cable suitable for outdoor use reduces the risk of electric shock.

PERSONAL SAFETY

1. **Stay alert, watch what you are doing and use common sense when operating a power tool.** Do not use a power tool while you are tired or under the influence of drugs, alcohol or medication. A moment of inattention while operating power tools may result in personal injury.

2. **Use personal protective equipment.** Always wear eye protection. Safety equipment such as dust mask, non-skid safety shoes, hearing protection and a workshop apron capable of stopping small abrasive or workpiece fragments.
3. **Avoid accidental starting.** Ensure the switch is in the off position before plugging in. Plugging in power tools that have the switch on invites accidents.
4. **Remove any adjusting key or wrench before turning the power tool on.** A wrench or a key left attached to a rotating part of the power tool may result in personal injury.
5. **Do not overreach.** Keep proper footing and balance at all times. This enables better control of the power tool in unexpected situations. Dress properly. Do not wear loose clothing or jewellery.
6. Keep your hair, clothing and gloves away from moving parts. Loose clothes, jewellery or long hair can be caught in moving parts. Keep the work area clean and tidy.
7. Regularly clean the power tool's air vents. The motor fan will draw dust inside the housing and accumulation of material could cause electrical hazards.
8. **Avoid operator fatigue.** Stop the power tool at regular intervals for a short break to rest hands and arms.
9. **Maintain your tools.** Keep all handles and grips dry and clean.

ELECTRICAL SAFETY

1. Position the power cable so that it cannot be inadvertently pulled or pinched, and where it does not cause a trip hazard.
2. This machine is designed for indoor environments and must not be used for other purposes.
3. If the machine requires repair, always contact your Clarke dealer. Always insist on original spare parts. Repairs carried out by unauthorized persons may be dangerous and invalidate the guarantee.
4. This machine must only be used by adults. Children should not be allowed to play with this appliance.
5. Never use the machine if the electric cable or plug is in poor condition.
6. Do not use extension power cables.
7. Before cleaning or maintenance operations, always unplug the machine from the power supply.

POWER TOOL USE AND CARE

1. **Do not force the machine.** Use the correct power tool for your application. It will do a better and safer job at the rate for which it was designed.
2. **Do not use the power tool if the switch does not turn it on and off.** Any power tool that cannot be controlled with the switch is dangerous and must be repaired.
3. **Disconnect the power tool from the power supply before making any adjustments, changing accessories, or storing the tool.** These measures will reduce the risk of the power tool starting accidentally.
4. **Store power tools out of the reach of children and do not allow persons unfamiliar with these instructions to operate the power tool.** Power tools are potentially dangerous in the hands of untrained users.
5. **Maintain power tools in top condition.** Keep tools/ machines clean for the best and safest performance. Check for misalignment or binding of moving parts, broken parts, or any condition that may affect the power tool's operation. If damaged, have the power tool repaired before use. Many accidents are caused by poorly maintained power tools.
6. **Use recommended accessories.** The use of improper accessories could be hazardous.
7. **Machine cleanliness.** Do not allow the ventilation slots in the machine to become blocked with dust.
8. **Check the power tool for damage before using the machine.** Any damaged part should be inspected to ensure that it will operate properly and perform its intended function. Check for alignment of moving parts, breakage of parts, mountings, and any other condition that may affect the machine's operation. Any damage should be properly repaired or the part replaced. If in doubt, DO NOT use the machine. Consult your local dealer.

SERVICING

1. **When necessary, have your power tools serviced or repaired by a qualified person using identical replacement parts.** This will ensure that the safety of the power tool is maintained.

ADDITIONAL PRECAUTIONS FOR BANDSAWS

1. Always check safety guards are in place and functioning correctly before switching the machine on.
2. Always use a push stick & fence for small workpieces wherever practical.
3. Always use the appropriate saw blade for the material being cut.
4. Never touch the blade immediately after use, when changing the blade always allow time for it to cool.

5. Never use damaged blades. (Replacement blades are available from your Clarke dealer.
6. Never attempt any maintenance or adjustments of the saw band when it is in motion.
7. Do not remove jammed cut -off pieces until the blade has stopped.
8. Replace table insert if the slot has become enlarged.
9. When cutting wood, ensure all nails or fastenings have been removed beforehand. Nails will damage the saw blade.
10. When cutting round timber stock, use a suitable jig or fixture to keep the work from turning.
11. Always ensure the blade is fully tightened and correctly adjusted before use.
12. Keep the mains cable well away from the working parts of the machine and ensure an adequate electrical supply is close at hand so that the operation is not restricted by the length of the cable.
13. Switch the machine off as soon as the task is completed.

SAFETY SYMBOLS

The following safety symbols may be found on the machine.



Wear a dust mask



Wear eye protection



Read instruction manual before use

SPECIFICATIONS

	CBS225
Weight	21 kg
Dimensions (W x D x H)	490 x 420 x 830 mm
Table Size (W x D)	300 x 300 mm
Throat Width	228 mm
Table Tilt Angle	0 - 45°
Mitre Gauge Range	Left 60° / Right 60°
Maximum Cutting Depth @ 90°	90 mm
Maximum Cutting Depth @ 45°	50 mm
Height of Fence	52 mm
Power supply	230V - 50Hz
Rated Power @230V	300 W
Motor speed	1400 rpm
Blade Speeds	10.6 m/sec
Duty Cycle	S1 continuous
Sound Pressure Level (Lp)	70.7 dB(A)
Sound Power Level Measured (Lw)	83.7 dB(A)
Blade dimensions	
Blade Length (welded loop)	1575 mm
Blade Width	10 mm
Blade Tooth Pitch	10 tpi
Blade thickness	0.35 mm

ELECTRICAL CONNECTIONS



WARNING! Read these electrical safety instructions thoroughly before connecting the product to the mains supply.

Before switching the product on, make sure that the voltage of your electricity supply is the same as that indicated on the rating plate. This product is designed to operate on 230VAC 50Hz. Connecting it to any other power source may cause damage.

This product may be fitted with a non-rewireable plug. If it is necessary to change the fuse in the plug, the fuse cover must be refitted. If the fuse cover becomes lost or damaged, the plug must not be used until a suitable replacement is obtained.

If the plug has to be changed because it is not suitable for your socket, or due to damage, it should be cut off and a replacement fitted, following the wiring instructions shown below. The old plug must be disposed of safely, as insertion into a mains socket could cause an electrical hazard.



**WARNING! The wires in the power cable of this product are coloured in accordance with the following code:
Blue = Neutral Brown = Live Yellow and Green = Earth**

If the colours of the wires in the power cable of this product do not correspond with the markings on the terminals of your plug, proceed as follows.

- The wire which is coloured **Blue** must be connected to the terminal which is marked **N** or coloured **Black**.
- The wire which is coloured **Brown** must be connected to the terminal which is marked **L** or coloured **Red**.
- The wire which is coloured **Yellow and Green** must be connected to the terminal which is marked **E** or  or coloured **Green**.

Plug must be BS1363/A approved.

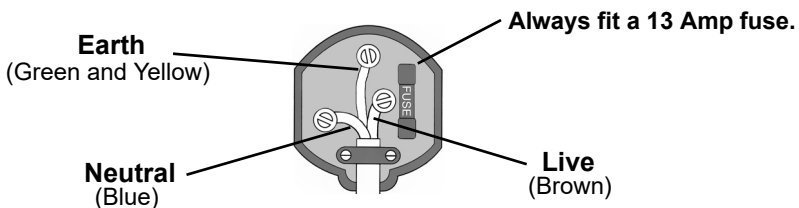

Ensure that the outer sheath of the cable is firmly held by the clamp

We strongly recommend that this machine is connected to the mains supply via a Residual Current Device (RCD)

If in any doubt, consult a qualified electrician. DO NOT attempt any repairs yourself.

OVERVIEW

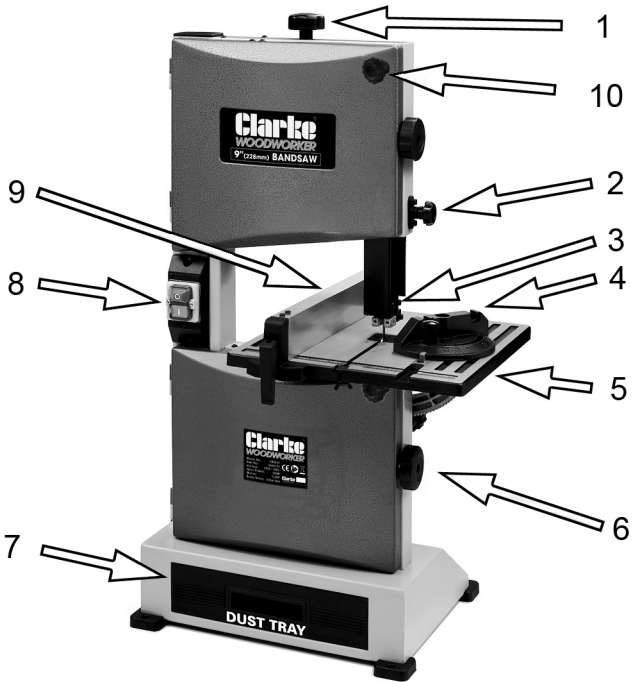

No	DESCRIPTION
1	Blade Tension Setting Knob
2	Guide Height Setting Knob
3	Upper Blade Guide
4	Mitre Gauge Assembly
5	Tilting Work Table

No	DESCRIPTION
6	Cover Release knob
7	Dust Tray
8	Start/Stop buttons
9	Rip Fence Assembly
10	Cover Safety Latch

CONTENTS

Make sure that all parts are un-damaged and are present. If any parts are missing or damaged please contact your CLARKE dealer immediately.

The following loose components are supplied with the bandsaw assembly.

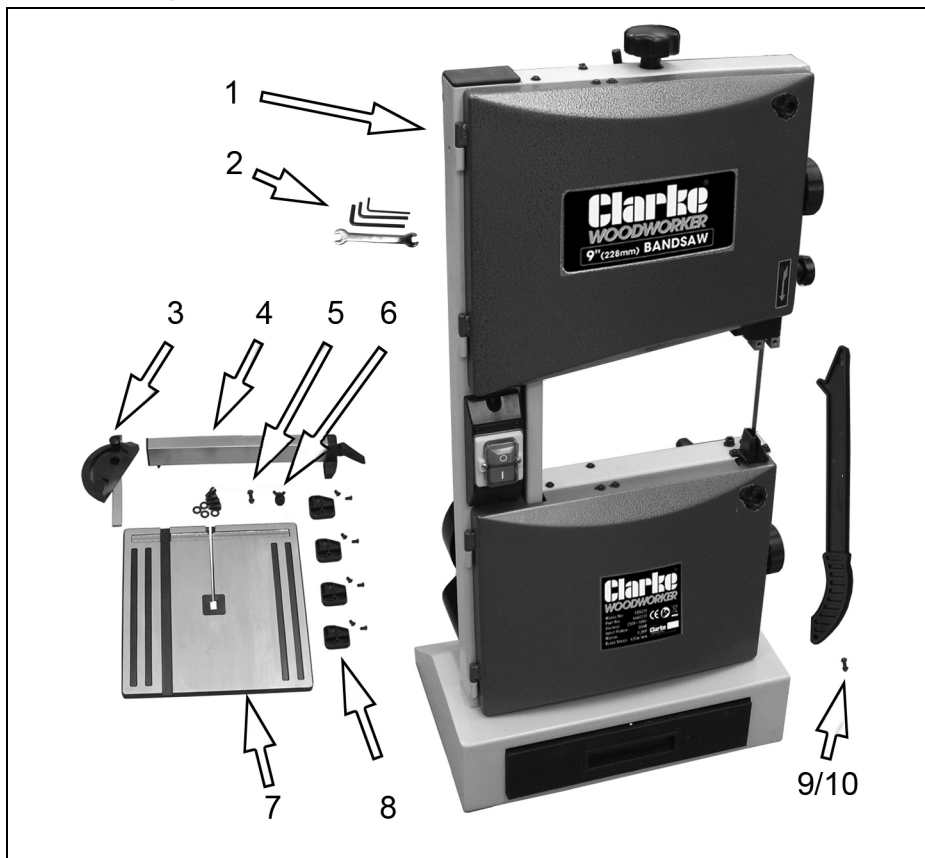

ITEM	DESCRIPTION
1	Bandsaw Assembly
2	Key/Spanner Set
3	Mitre Guide Assembly
4	Parallel Fence Assembly
5	Table Stop bolt

ITEM	DESCRIPTION
6	D-piece/wing screw
7	Table
8	Polymer Foot c/w screws
9	Push Stick
10	Push Stick Hook & nut

ASSEMBLY

PREPARATION

For maximum stability the bandsaw should be bolted firmly to either a workbench, a suitable stand, or a piece of plywood, 5/8" thick, and the plywood should be clamped firmly to a workbench, using clamps, whenever the bandsaw is being used.

The saw must be located in an area large enough to allow you to work freely, taking into account the likely size of your workpiece, and that there should be adequate lighting.

Make sure also that an adequate electrical supply is close by. Take extra care if extension leads are used. Make sure that there is no possibility of tripping over the lead when moving around the work area.

FITTING THE TABLE

1. Rest the bandsaw on its side, supported by a block of timber and protect the casing from damage with cardboard. Fit the feet to the bandsaw using the pan head screws and washers.
2. Remove the D-nut and wing screw from the table (if fitted).
3. Fit the table to the bandsaw using socket head M8 x 14 bolts and 8mm flat washers. Ensure the saw blade is central in the table slot.
4. Screw the table stop bolt into the underneath of the table.
5. Re-fit the D-nut and wing screw to the table.
6. Fit the push stick hook to the side of the machine and tighten using the locking nut.
7. Hang the push stick on the hook.

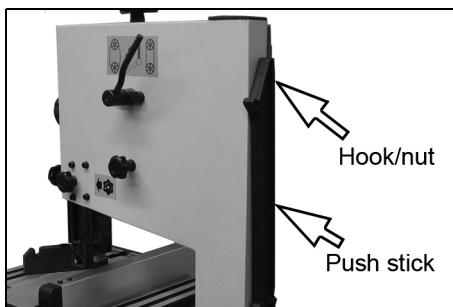
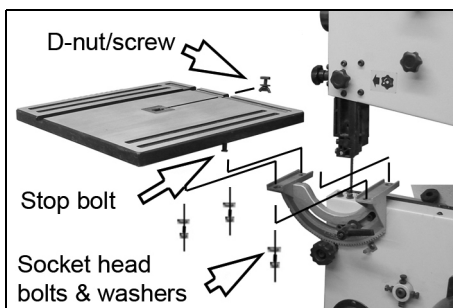

8. Fit the rip fence to the table if required.
9. Slide the mitre gauge into the slot in the table if required.

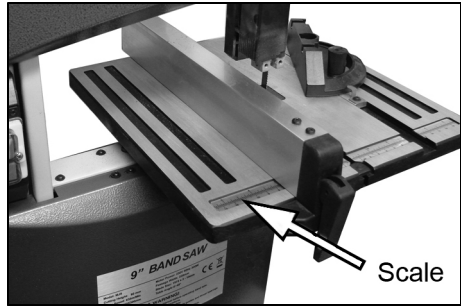

ADJUSTING THE COMPONENTS

TILTING THE TABLE

1. Loosen the locking handle and turn the table tilting knob to adjust the table to the desired angle.
 2. Use the angle indicator scale on the table tilting bracket, to find the desired angle.
 3. Re-tighten the locking handle to secure the table.
- For assured accuracy, we recommend checking the tilt angle using a protractor or set square.
4. With the table exactly level, it should rest on the supporting bolt shown. Adjust the height of the bolt by screwing it in or out of the table and securing with the locknut. Check with a set square that the table is exactly level when resting on the bolt.

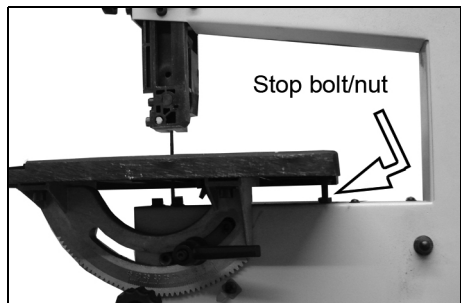
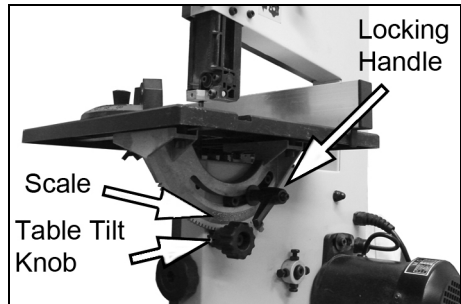

TRACKING THE SAW BLADE

1. Open the upper and lower covers by releasing the twist knobs and the safety latches on the front of the machine.
 - Unscrew the safety latches fully to release the cover panels.
 - The panels will not move unless the twist knobs are first released.
2. Manually rotate the upper wheel, taking care of the sharp blade.

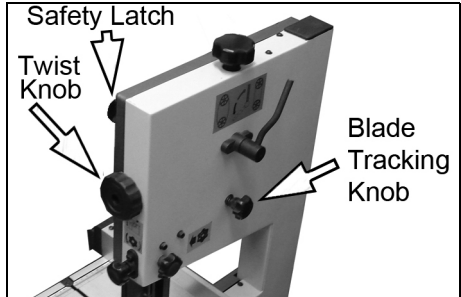

If the saw blade does not run on the centre of the rubber tyre the tracking needs to be corrected before use by adjusting the tilt angle of the upper bandsaw wheel.

3. Turn the blade tracking knob clockwise or anticlockwise until the saw blade tracks centrally on the rubber tyre of both wheels.
4. After adjusting, close both covers.

ADJUSTING THE BLADE TENSION



CAUTION: TOO MUCH TENSION CAN CAUSE THE SAW BLADE TO BREAK. TOO LITTLE TENSION CAN CAUSE THE BLADE TO MAKE IRREGULAR (WANEY) CUTS.

1. Raise the upper blade guide fully by twisting the guide setting knob.
2. Check the tension by pressing with a finger against the side of the blade, halfway between the table and upper guide.
 - The blade should not flex sideways by more than 2 mm at its longest span.
3. Turn the blade tension knob to adjust the tension.
 - Turning the blade tension knob clockwise will increase the blade tension.

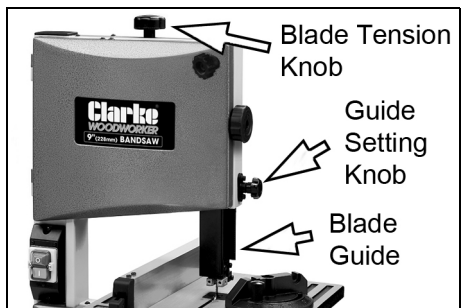

BLADE GUIDES / BEARING SETTING

The upper and lower blade guides need to be re-adjusted after any blade change or tracking adjustment.

This task may be easier if the table is tilted for better access.

1. Loosen the set-screws (A) and position the guide pins 0.5 mm from the blade. Tighten the set screws.

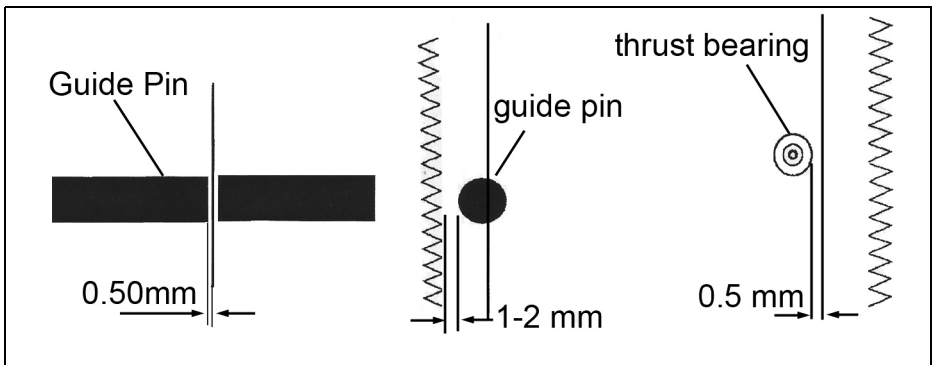
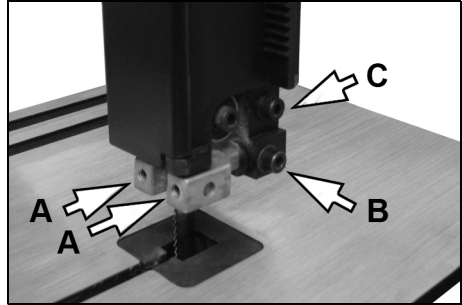

2. Loosen the socket-headed bolt (B) and adjust guide pin carrier position, so that guide pins are positioned 1- 2mm from teeth of blade. Retighten the socket-headed bolt (B).
 3. Loosen the socket-headed bolt (C), and adjust the thrust bearing to a position of 0.5mm from rear edge of the blade. Retighten the bolt (C).
 4. Repeat the process with the lower blade guide located in the lower section of the bandsaw.
- Note that the lower guide assembly is identical but installed upside-down, and that access to the socket-headed bolts (B and C) is through the holes provided.

UPPER BLADE GUIDE ADJUSTMENT

The height of the upper blade guide needs to be adjusted prior to every cutting operation to accommodate the height of the workpiece.

The upper blade guide should be set approx 3 mm above the workpiece.

Set the upper blade guide by turning the adjusting knob to the desired height and securing in position with the locking knob.

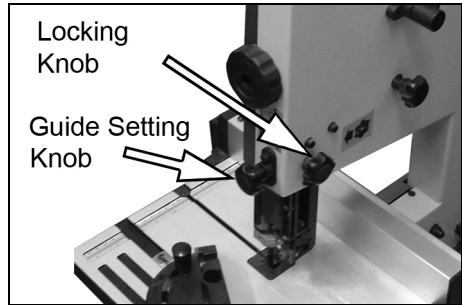

PREPARING FOR WORK

1. Press the green button to start the bandsaw.
2. Press the red button to stop the machine at any time.

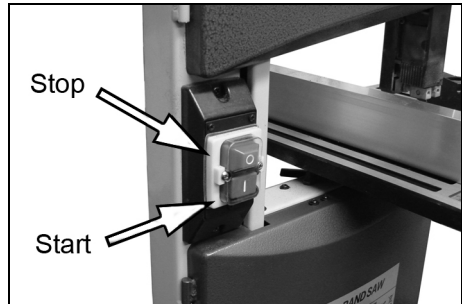

USING THE FENCE

The fence can be used on both sides of the blade.

1. Engage the fence with the table and move to the required position. The scale indicates the distance from the saw blade to the fence.
2. Ensure the fence is parallel with the grooves in the table.
3. Press down the locking lever to clamp the fence in position.

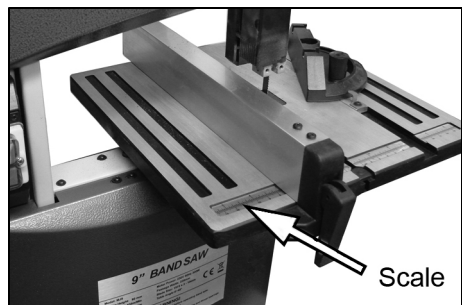

USING THE MITRE GAUGE

The mitre gauge is inserted into the table slot from either edge.

1. To set a mitre angle, loosen the lock knob by turning it counter-clockwise.
 - The mitre gauge can be turned to max 60° in both directions.
2. Firmly tighten the knob to secure the mitre gauge in position.

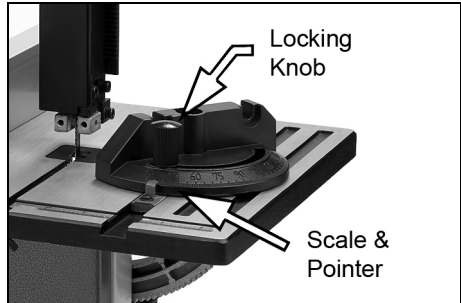

CONNECTING TO A DUST COLLECTOR

This bandsaw is fitted with a dust port for connection to a dust collector if available.

- The connector size is 48 mm i/d (53 mm o/d)

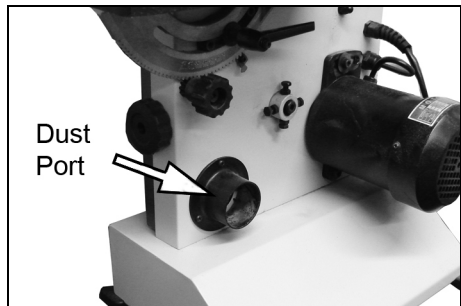

Other sawdust will fall into the dust drawer which can be removed and emptied as required. This is best cleared out regularly.



USING THE PUSH STICK

The push-stick serves as an extension of the operators hand as protection against accidentally touching the saw blade.

The push-stick should be used if the rip fence is close to the blade.

When not in use, the push-stick can be stored on the hook provided on the bandsaw frame.

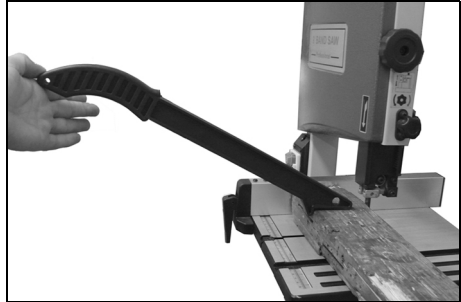

PRACTICAL OPERATION

Before commencing work, ensure the work area is clean and tidy and the machine table is clear of tools etc. Plan your work carefully and set the machine up accordingly before switching on.

- Check the blade is correctly tensioned before use (see page 13).
- Set the upper blade guide as close as practical to the workpiece. This provides the best safety for the operator and giving more accurate results and greater control.
- Adjust the height of the upper blade guide to achieve the best control. The guide should always be set to just clear the top of the workpiece.
- Switch on and allow the saw blade to reach full speed before proceeding.
- Use both hands to feed the workpiece. The work must be held flat on the table at all times to prevent binding of the blade. Use a steady, even pressure, just sufficient to keep the blade cutting.
- Always use the rip fence or mitre gauge where possible to eliminate any sideways movement of the work. This is most important when the table is tilted at an angle.
- Remember that the blade removes material during the cut creating a gap called the 'kerf', which must be allowed for when cutting to exact sizes. Plan your cut so that the kerf is the scrap side of the line you wish to cut. Where necessary, allow a little more material for finishing.
- Always use a suitable holding device when cutting round or irregular shaped timber to prevent twisting of the work piece.

TYPES OF CUT

Several types of cut are possible with this saw i.e. rip cutting, cross cutting, bevel or mitre cutting.

RIP CUTTING

This term refers to cutting timber in the same direction as the grain, rather than across it. You can rip wood freehand to a drawn pencil line, but best results are obtained by using the rip fence.

If the table is set level, set the rip-fence to the left hand side of the blade, allowing you to use your right hand to hold the work firmly against the fence.

The scale on the fence guide rail indicates the distance of the fence from the saw blade and can be used as shown on page 15.

When cutting a bevel rip, with the table tilted at any angle up to 45°, set the rip fence to the right hand side of the blade if the width of the workpiece allows it. With the fence on the 'downhill' side of the table, it will help support the workpiece.

The width of cut indicator (scale) on the guide rail may be used to set the rip fence to the required cutting position.

Long workpieces may require additional support in the form of blocks or rollers and may be pulled as well as pushed to pass them through the bandsaw.

CROSS CUTTING

This term refers to cutting timber at right angles to the grain. This type of cut can also be made freehand, but the mitre gauge is used to ensure accurate results. The mitre gauge can be adjusted up to 60° to produce mitre cuts, and with the table tilted, compound mitre cuts.

Make sure the work is held firmly against the table and against the face of the mitre gauge. Be careful to keep your fingers away from the blade, particularly at the end of the cut.

MITRE CUTTING

Most crosscut work, especially with small pieces is more easily controlled with the use of a mitre gauge. The mitre gauge is also essential for accurate compound mitre cuts. The gauge is graduated to 60° for both left and right hand angles.

FREEHAND CUTTING

The ease with which many different and varied shapes can be cut is one of the most important features of the bandsaw.

When freehand cutting, always feed the work slowly so that the blade can follow the line you wish to cut. Make sure not to drag the work off line, forcing the blade sideways, or twisting it.

In many cases, it is helpful to rough cut about 6mm away from the line. For difficult curves which may be too tight for the blade, make relief cuts at 90° to the face of the curve so that these scraps will fall away as the final radius is sawn.

Each blade has a minimum radius which it will be able to cut, dependant upon its width. The blade supplied is 10mm wide and able to cut as little as 50mm radius, beyond which the stress may cause it to break. If using a different blade, a bandsaw blade radius chart should be consulted.

MAINTENANCE



WARNING: ALWAYS SWITCH OFF THE MACHINE AND DISCONNECT FROM THE POWER SUPPLY BEFORE CARRYING OUT ANY CLEANING OR MAINTENANCE TASKS.

CLEANING

Accumulated dust and chips should be removed from inside the bandsaw frequently as well as emptying the dust drawer. Open the upper and lower covers, use a soft brush and/or vacuum cleaner to remove sawdust. If compressed air is used, ensure it is set to no more than 10 psi.

At the end of every work session, clean sawdust away from the motor vents.

CHANGING THE SAW BLADE



WARNING: THE TEETH OF THE BLADE ARE SHARP. TAKE CARE WHEN HANDLING THE BLADE IN SITUATIONS SUCH AS UNPACKING, MOUNTING OR REPLACING.

1. Remove the D-nut/screw from the table.
2. Open the upper and lower covers.
3. Set the upper blade guide to its lowest position.
4. Loosen the quick-release lever until the saw blade has slackened.
5. Remove the saw blade from the machine.
6. Fit a fresh saw blade, passing it behind the side guard and aligning it with the upper and lower blade guides. Centre the blade on the rubber tyres of the wheels. Ensure the teeth are pointing downwards towards the table.
7. Tighten the quick release lever.

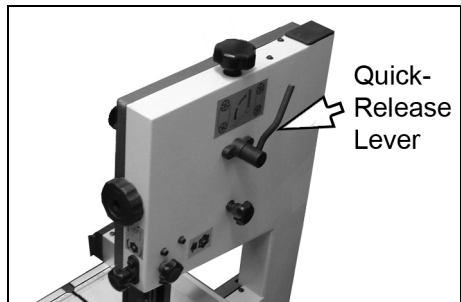
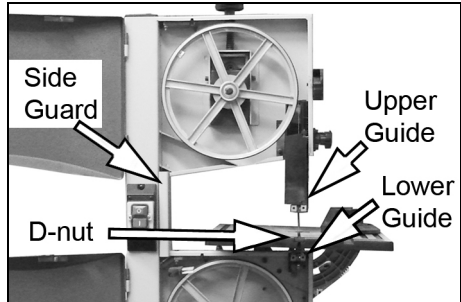

8. Set the blade tracking as described on page 13.
9. Close the upper & lower covers.
10. Adjust the blade tension as described on page 13.
11. Adjust the upper and lower blade guide as described on pages 13/14.

CHANGING THE WHEEL PULLEY TYRES

Eventually the rubber tyres on the bandsaw pulley wheels may wear due to the constant contact with the blade. Remove the saw blade as described on page 20, then lift the edge of the tyre with a small screwdriver and carefully work off the wheel. Ease on the new tyre, ensuring it sits evenly around the wheel.

We recommend that both tyres are changed at the same time.

BLADE GUIDES

Blade guides should be inspected regularly for wear or chipping, and replaced if necessary. See page 14 for blade guide adjustments.

BEARINGS

All bearings used in the construction of your bandsaw and its motor are sealed and lubricated for life.

STORAGE

Switch off the bandsaw and disconnect the power cable.

Cover the machine with a plastic bag and store it in a dry location.

OPTIONAL ACCESSORIES

REPLACEMENT BLADES

Suitable blades are available from your Clarke stockist:

- 6tpi Bandsaw blade: Part No6458005
- 10tpi Bandsaw blade: Part No6458000

DUST EXTRACTORS

A choice of dust extractors is available for this bandsaw including

CDE35 Portable Dust Extractor & Chip Collector

CDE1000 Portable Dust Extractor

TROUBLESHOOTING

FAULT	CHECK	SOLUTION
The unit fails to operate	<ol style="list-style-type: none"> 1. Check for power failure if the unit is plugged in. 2. Check the switch is on and that the fuse is not blown. 3. Upper or lower door interlock switch not engaged. 	<ol style="list-style-type: none"> 1. Plug the unit into the socket. 2. Replace fuse or switch on. 3. Check that upper/lower doors are fully closed using the safety latches.
Blade breaks	<ol style="list-style-type: none"> 1. Faulty alignment (tracking) 2. Blade guides incorrectly adjusted. 3. Feeding the work too fast. 4. Forcing or twisting the blade around a tight radius. 5. Blade too tight. 6. Blunt teeth. 7. Blade is badly welded or brazed. 8. Wrong blade fitted. 9. Bandsaw left running when not in use. 	<ol style="list-style-type: none"> 1. Carry out tracking adjustments (p13). 2. Re-adjust blade guides (p14/15) 3. Lower the feed rate 4. For tight curves, make relief cuts fairly close together at 90° to the curve. A narrower blade will make a tighter curve. 5. Relieve blade tension 6. Renew blade 7. Renew blade 8. Fit only quality blades supplied by your Clarke dealer. 9. Always switch machine off when not in use.
Noise or vibration	<ol style="list-style-type: none"> 1. Blade not correctly aligned. 2. Guides not securely set. 	<ol style="list-style-type: none"> 1. Carry out tracking adjustments (p13). 2. Tighten the locking knob. Check guides are correctly set.
Blade runs off the cutting line	<ol style="list-style-type: none"> 1. Blade guides incorrectly adjusted. 2. Blade tracking mal-adjusted 3. Blade tension too slack. 4. Wrong blade fitted (too thin). 	<ol style="list-style-type: none"> 1. Re-adjust blade guides. 2. Carry out tracking adjustment (p13). 3. Re-tension blade. 4. Fit correct blade.

PARTS DIAGRAM

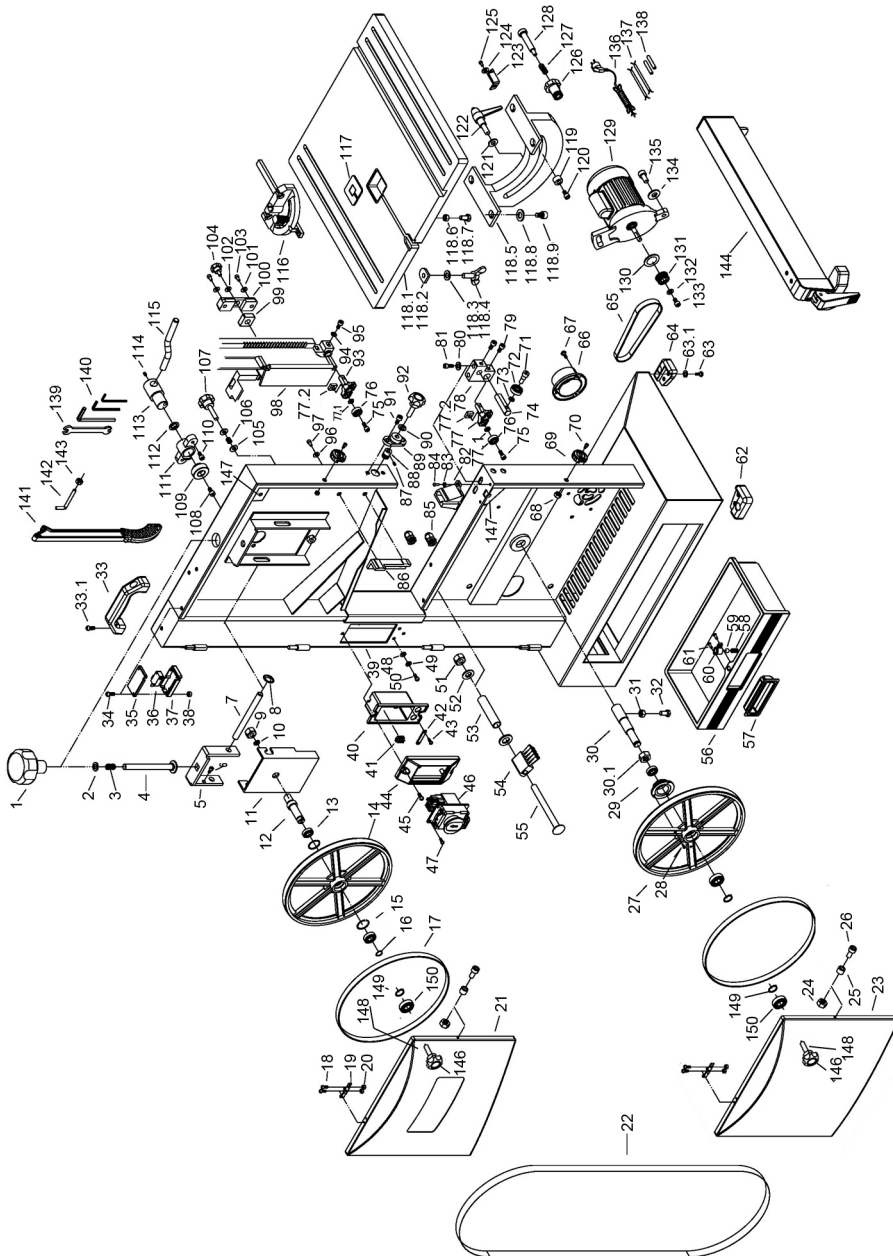

PARTS LIST

PART NO	DESCRIPTION	PART NO	DESCRIPTION
1	Blade tension knob	35	Cover
2	Flat washer 8 mm	36	Interlock switch
3	Blade tension spring	37	Interlock switch box
4	Carriage bolt M8 x 80	38	Nut M4
5	Pulling plate	39	Frame
6	Socket head screw M5x8	40	Switch box
7	Shaft	41	Connecting terminal
8	Lock Catch	42	Cable clamp
9	Hex nut M10	43	Self tapping screw
10	Lock washer 10mm	44	Switch mounting plate
11	Bevel support plate	45	Pan head screw M5 x 10
12	Upper wheel shaft	46	Switch
13	Ball bearing 6000ZZ	47	Self tapping screw
14	Upper Wheel	48	Lock washer 5mm
15	Internal circlip 26mm	49	Serrated washer 5mm
16	External circlip 10mm	50	Pan head screw M5 x 10
17	Tyre	51	Nut M8
18	Pan head screw M4x10	52	Flat washer 8mm
19	Interlock switch key	53	Bush
20	Nut M4	54	Brush
21	Upper wheel cover	55	Carriage bolt M8 x 65
22	Blade (1575mm x 10tpi)	56	Dust drawer
23	Lower wheel cover	57	Drawer handle
24	Lock nut M6	58	Spring
25	Bushing	59	Ball
26	Socket head screw M6 x 16	60	Ball housing
27	Lower wheel	61	Self tapping screw
28	ST screw	62	Foot
29	Driven pulley	63	Pan head screw /washer 5mm
30	Lower wheel shaft	64	Foot
31/30.1	Locknut M12/Nut M6	65	Drive belt
32	Bolt M6 x 16	66	Dust port
33	Lifting handle/screw M6 x 10	67	Pan head screw M5 x 8
34	Pan head screw M4 x 25	68	Locknut M6

PARTS LIST

PART NO	DESCRIPTION	PART NO	DESCRIPTION
69	Catching knob	103	Socket head screw M5x10
70	Socket head screw M6x16	104	Locking knob
71	Socket head screw	105	Flat washer 8mm
72	Bearing 606-ZZ	106	Spring
73	Flat washer 5mm	107	Tracking knob
74	Support rod	108	Socket head screw M6x16
75	Socket head screw M5x14	109	Release block
76	Bearing 605ZZ	110	Socket head screw M5x10
77	Lower guide block/washer/nut	111	Sleeve
78	Guide block support	112	Wave washer
79	Socket head screw M5x12	113	Shaft
80	Flat washer 6mm	114	Set screw M5x6
81	Socket head screw M5x10	115	Release handle
82	Lower protective cover	116	Mitre gauge assembly
83	Flat washer 4mm	117	Table insert
84	Pan head screw M4x10	118.1	Table
85	Strain relief	118.2	D-Nut
86	Guide plate	118.3	Flat washer 6mm
87	Set screw M4x6	118.4	Wing screw
88	Pinion	118.5	Bevel case
89	Adjustment knob seat	118.6	Hex nut M6
90	Flat washer 6mm	118.7	Hex bolt M6x22
91	Socket head screw M5x10	118.8	Flat washer
92	Adjustment knob	118.9	Socket head screw M8x14
93	Upper guide block	119	Guide bushing
94	Flat washer 5mm	120	Socket head screw M6x12
95	Socket head screw M5x12	121	Flat washer 8mm
96	Flat washer 5mm	122	Locking handle
97	Socket head screw M5x10	123	Pointer
98	Upper protective cover	124	Flat washer 5mm
99	Square nut	125	Pan head screw M5x10
100	Guide block	126	Table adjusting handle
101	Flat washer 5mm	127	Spring
102	Flat washer 8mm	128	Table adjusting handle

PARTS LIST

PART NO	DESCRIPTION	PART NO	DESCRIPTION
129	Motor	140	Hex wrench 4mm, 6mm
130	Sponge ring	141	Push stick
131	Motor pulley	142	Hook
132	Flat washer 5mm	143	Hex nut
133	Socket head screw M6x12	144	Rip fence assembly
134	Flat washer 8mm	146	Safety Latch Knob
135	Socket head screw M8x25	147	Safety Switch
136	Power cable	148	Latch Bolt
137	Inner wiring	149	Circlip
138	Protective sleeve	150	Bushing
139	Spanner		

DECLARATION OF CONFORMITY



Clarke[®]
INTERNATIONAL

Hemnall Street, Epping, Essex CM16 4LG

DECLARATION OF CONFORMITY

This is an important document and should be retained.

We hereby declare that this product(s) complies with the following directive(s):

- 2014/30/EU *Electromagnetic Compatibility Directive.*
2006/42/EC *Machinery Directive.*
2011/65/EU *Restriction of Hazardous Substances (amended by (EU) 2015/863).*

The following standards have been applied to the product(s):

- EN 61029-1:2009+A11:2010, EN 61029-2-5:2011, EN 55014-1:2017, EN 55014-2:2015,
EN 61000-3-2:2014, EN 61000-3-3:2013.*

The technical documentation required to demonstrate that the product(s) meet(s) the requirement(s) of the aforementioned directive(s) has been compiled and is available for inspection by the relevant enforcement authorities. Annex IV: Notified Body: TUV SUD Product Service GmbH, Ridlerstrabe 65. D-80339 Munchen, Germany. EC Type-Examination Certificate No.: M6A 16 12 28954 064. Notified Body No.: 0123

The CE mark was first applied in: 2015

Product Description: 228mm (9") Band Saw
Model number(s): CBS225
Serial / batch Number: N/A
Date of issue: 21/07/2020

Signed:

J.A. Clarke
Director

A SELECTION FROM THE VAST RANGE OF

Clarke®

QUALITY PRODUCTS



AIR COMPRESSORS

From DIY to industrial, Plus air tools, spray guns and accessories.

GENERATORS

Prime duty or emergency standby for business, home and leisure.

POWER WASHERS

Hot and cold, electric and engine driven - we have what you need

WELDERS

Mig, Arc, Tig and Spot. From DIY to auto/industrial.

METALWORKING

Drills, grinders and saws for DIY and professional use.

WOODWORKING

Saws, sanders, lathes, mortisers and dust extraction.

HYDRAULICS

Cranes, body repair kits, transmission jacks for all types of workshop use.

WATER PUMPS

Submersible, electric and engine driven for DIY, agriculture and industry.

POWERTOOLS

Angle grinders, cordless drill sets, saws and sanders.

STARTERS/CHARGERS

All sizes for car and commercial use.



PARTS & SERVICE: 0208 988 7400

Parts Enquiries
Parts@clarkeinternational.com

Servicing & Technical Enquiries
Service@clarkeinternational.com

SALES: UK 01992 565333 or Export 00 44 (0)1992 565335

Clarke® INTERNATIONAL Hemnall Street, Epping, Essex CM16 4LG
www.clarkeinternational.com